

DAVEY WATER PRODUCTS LIMITED WARRANTY

1. The guarantee period commences on the date of original purchase of the equipment. Evidence of this date of original purchase must be provided when claiming repairs under guarantee. It is recommended you retain all receipts in a safe place.
2. Davey products are warranted to the original user only to be free of defects in material and workmanship for a period of 12 months from date of installation, but no more than 24 months from date of manufacture. Davey's liability under this warranty shall be limited to repairing or replacing at Davey's option, without charge, FOB Davey's distribution center or authorized service agent. Davey will not be liable for any costs of removal, installation, transport or any other charges that may arise in connection with the warranty claim.
3. This guarantee is subject to due compliance by the original purchaser with all directions and conditions set out in the Installation and Operating Instructions. Failure to comply with these Instructions, damage or breakdown caused by fair wear and tear, negligence, misuse, incorrect installation, inappropriate chemicals or additives in the water, inadequate protection against freezing, rain or other adverse weather conditions, corrosive or abrasive water, lightning or high voltage spikes or through unauthorized persons attempting repairs are not covered under guarantee. The product must only be connected to the voltage shown on the nameplate.
4. Davey shall not be liable for any loss of profits or any consequential, indirect or special loss, damage or injury of any kind whatsoever arising directly or indirectly from the product or any defect, and the purchaser shall indemnify Davey against any claim by any other person whatsoever in respect of any such loss, damage or injury.
5. Some states do not allow the exclusion or limitation of incidental or consequential damages or limitations on how long an implied warranty lasts, so the above limitations or exclusions may not apply to you. The warranty gives you specific legal rights and you may also have other rights which vary from state to state.
6. This guarantee applies to all states and territories of United States of America and Canada only.

® Davey is registered trademark of Davey Water Products Pty Ltd.
© Davey Water Products Pty Ltd 2007



Installation and Operating Instructions for Davey BF Series Pressure Booster Systems with Flow Switch Control



Davey Water Products Pty Ltd

Member of the GUD Group
ABN 18 066 327 517

Offices

Melbourne • Sydney • Brisbane • Adelaide • Perth • Townsville
New Zealand • Germany

U.S.A. - Davey Pumps Inc.

1005N. Commons Drive, Aurora, Illinois 60504
Ph: +1 630 898 6976 Fax: +1 630 851 7744
Website: daveyusa.com
E-mail: sales@daveyusa.com

P/N 401342-2 supersedes P/N 401342-1



NOTE: Prior to installation remove the red transport plugs & associated seals from the suction and/or discharge ports.



WARNING : The Flow Switch controller, pump and associated pipework operate under pressure. Under no circumstances should the Flow Switch controller, pump or associated pipework be disassembled unless the internal pressure of the unit has been relieved. Failure to observe this warning will expose persons to the possibility of personal injury and may also result in damage to the pump, pipework or other property.



WARNING: Failure to follow these instructions and comply with all applicable codes may cause serious bodily injury and/or property damage.

Please pass these instructions on to the operator of this equipment.



Prior to using this pump you must ensure that:

- The pump is installed in a safe and dry environment
- The pump enclosure has adequate drainage in the event of leakage
- Any transport plugs are removed
- The pipe-work is correctly sealed and supported
- The pump is primed correctly
- The power supply is correctly connected
- All steps have been taken for safe operation

Appropriate details for all of these items are contained in the following Installation and Operating Instructions. Read these in their entirety before switching on this pump. If you are uncertain as to any of these Installation and Operating Instructions please contact your Davey dealer or the Davey office as listed on the back of this document.

Congratulations on your purchase of a high quality, Davey pressure booster system. All components have been designed and manufactured to give trouble free, reliable operation.

Your new pressure booster system incorporates a flow sensor which enables the use of a highly efficient pump design and offers the following benefits:

1. Enables the pump to deliver a constant flow of water particularly at low flow rates - reducing the inconvenience of pressure variation in showers. It achieves this by sensing flow, not pressure.
2. Provides automatic "cut-out" protection to protect the pump should it run out of water preventing overheating*.

* Motor overload / overheat protection included. Motor has its own overload / overheat protection.

The Davey BF Series booster system is controlled by a flow sensor for starting and stopping the pump. This sensor is preset to turn on the pump at 1.2 GPM or more, and turn off the pump at 0.7 GPM or less. This is not adjustable and will boost your available pressure according to the table below:-

Model	Flow (gpm)	Boost (psi)
BT14-30	0	38
	10	32
	15	31
BT20-30	0	50
	10	41
	20	32
BT14-45	0	58
	10	48
	15	40
BT20-40	0	76
	10	63
	20	40

Trouble Shooting Check List continued...

PUMP SWITCHES ON AND OFF FREQUENTLY (CYCLING)

1. Leaking taps, float valves etc. check plumbing.
2. In a few isolated cases a “bounce back” effect on municipal water lines has been know to occur. By installing an expansion tank and check valve this problem is easily solved. Davey makes a kit part number “XF-KIT” for this problem which includes a tank, check valve, reducing tee and other pipe fittings. Please contact your Davey dealer for more information.

Note if a check valve is installed, a properly sized and located pressure relief valves, compression tanks, and other devices to compensate for thermal expansion must also be installed per local regulations.



NOTE: For protection, the Davey® pump motor is fitted with an automatic “over temperature” cut-out. Constant tripping of this overload device indicates a problem e.g. low voltage at pump, excessive temperature (above 115°F) in pump enclosure.



Motor normally operates at high temperature and may be too hot to touch. Before handling pump or motor, stop motor and allow it to cool.



WARNING: When servicing or attending pump, always ensure power is switched off and lead unplugged. Electrical connections should be serviced only by qualified persons.



Care should also be taken when servicing or disassembling pump to avoid possible injury from hot pressurized water. Unplug pump, relieve pressure by opening a tap on the discharge side of the pump and allow any hot water in the pump to cool before attempting to dismantle.



During servicing, use only approved, non-petrochemical based oring and gasket lubrication. If unsure, consult your Davey dealer for advice.



WARNING: Do not use hydrocarbon based or hydrocarbon propelled sprays around the electrical components of this pump.

After Sales Service

For professional after sales service or repair contact your Davey dealer. For assistance in locating your nearest dealer contact the Davey Service Center on 1-866-328-7867 or go to :-



This system can only be used in situations where existing water pressure is adequate to flow through pipe work at a rate of 1.2 GPM.

This unit can not be used in suction lift applications. For suction lift applications use Davey’s HS or BT series of pumps.



Before installing your new pump, please read all instructions carefully as failures caused by incorrect installation or operation are not covered by the guarantee. Your Davey pressure booster system is designed to handle clean water. The system should not be used for any other purpose without specific referral to Davey. The use of the system to pump flammable, corrosive and other materials of a hazardous nature is specifically excluded.

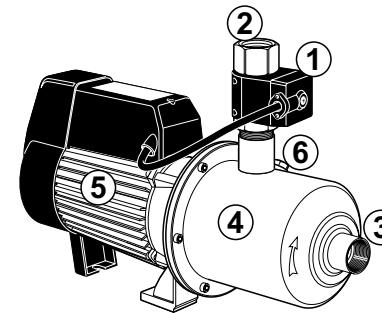

1. Flow Switch® Control Module
2. Discharge Outlet
3. Suction Inlet
4. Pump Body
5. Motor
6. Priming Plug (pump)

Preparing Your System

On removing your pressure booster flow switch system from its carton you will need to position the control module on top of the pump. Once in position on top of the pump, hand tighten into position. The control module can be rotated on the brass discharge to enable convenient positioning of the flow switch control onto the pump.

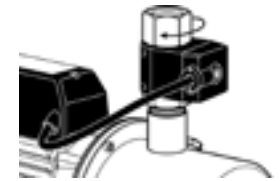

Only connect the discharge pipework to the discharge port.

Choosing a Site

Choose a site with a firm base and as close to the water source as possible with correct power supply. Make sure your pressure booster system is always connected to an adequate, reliable source of clean water.

Housing your Davey System

To protect your pressure booster system from the weather, make sure the pump house is both water proof, frost free and has adequate ventilation. The pump should be horizontally mounted on a firm base allowing for drainage, to avoid damage to flooring etc., that over time may occur from leaking pipe joints or pump seals. Do not mount the pump vertically. Never place flammable materials on or near your pump.

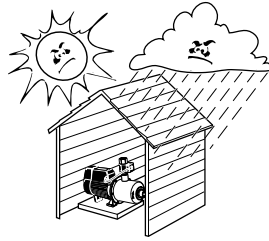

WARNING: Some insects, such as small ants, find electrical devices attractive for various reasons. If your pump enclosure is susceptible to insect infestation you should implement a suitable pest control plan.

Electrical Connection



The electrical connections and checks must be made by a qualified electrician and comply with applicable local standards. Poor installation or poor power supply may even result in electrical fires!



Connect power cord to power supply designated on pump label. Do not use long extension cords as they cause substantial voltage drop, poor pump performance and may cause motor overload.

BF14-30, BF20-30 and BF14-45 models are 115 volt 60Hz models, fitted with NEMA 5-15P plugs intended for direct connection to a three pin wall socket. BF20-40 models are 230 volt 60Hz only and are fitted with NEMA 6-15P plugs intended for direct connection to a 6-15R three pin wall socket. The color codes are: Green = Ground/Earth, Black = Hot, Active or L1, White = Neutral or L2.

Ensure that the circuit including the breakers on the power supply have sufficient capacity to accommodate pump starting amperage. Davey recommend a minimum circuit capacity of 20 amps for 115 volt models and 10 amps for 230 volt models.



Power connections and wiring must be carried out by an authorized electrician.



All wiring must conform to National (NEC), CSA, state, provincial, and local codes. Power supply voltage, phase and controls must match motor.



This pump is not to be used by children or infirm persons and must not be used as a toy by children.

The BF booster pump is supplied with the flow sensor uninstalled to the pump outlet. This requires the flow sensor to be attached to the outlet of the pump.

Use the thread tape supplied to seal the inlet thread. Do not use pipe sealant or pipe dope!

General Safety

1. To avoid risk of serious bodily injury and property damage, read the safety instructions carefully before installing this pump.
2. Follow local and/or national plumbing, building and electrical codes when installing the pump.
3. Hazardous Pressure. Do not use this pump with inlet pressure greater than 62psi. If local code requires installation of a pressure relief valve, follow the code requirements.
4. Never run the pump dry. To do so can damage internal parts, overheat pump and will void warranty.

Maintenance

Davey pumps are designed to provide years of trouble free service. It is recommended that periodic inspection be made to check for potential problems with the pump. If any leakage or evidence of leakage is present, the unit must be repaired. The mechanical seal in your pump is a wear part and over time might need to be replaced.

Where freezing may be a problem, all pipe work should be buried and/or insulated to prevent this from happening. Your Davey pump should be housed in an enclosure which does not experience temperatures below freezing (32°F).



FREEZING CONDITIONS: In situations subject to freezing, drain water from pump, tank & pipework to avoid damage not covered under guarantee.

Trouble Shooting Check List

PUMP WILL NOT START

Note: This is normal if the discharge flow is less than 1.2 GPM

1. Power is off, pump is unplugged, or no power at receptacle.
2. Stuck float in flow sensor. – Check for blockage or foreign material inside sensor.
3. Loose power connection.
4. Cracked reed switch on circuit board inside flow sensor.
5. Blocked impellers. – With power cord unplugged, remove fan cover and check that fan can turn freely.

PUMP WILL NOT STOP

Note: This is normal if discharge flow is greater than 0.7 gpm.

1. Flow greater than 0.7 GPM
2. Stuck float in flow sensor. – Check for blockage or foreign material inside sensor.
3. Water leaks on discharge side of pump.

PRESSURE DROPS WHEN PUMP STOPS

This is normal when no check valve is installed or if there are leaks less than 1.2 GPM.

Note if a check valve is installed, a properly sized and located pressure relief valves, compression tanks, and other devices to compensate for thermal expansion must also be installed per local regulations.

Adequately support the suction and discharge pipes by use of pipe hangers or anchors near the unit. For critical installations, equipment for absorbing expansion and vibration should be installed in the inlet and outlet connections of the unit. Make sure to install unions and shut off valves. Use Teflon tape on the flow sensor threads and suction pipe threads. Do not use pipe dope or paste.

 **BF Series pumps using flow switch is not recommended for whole home applications.**

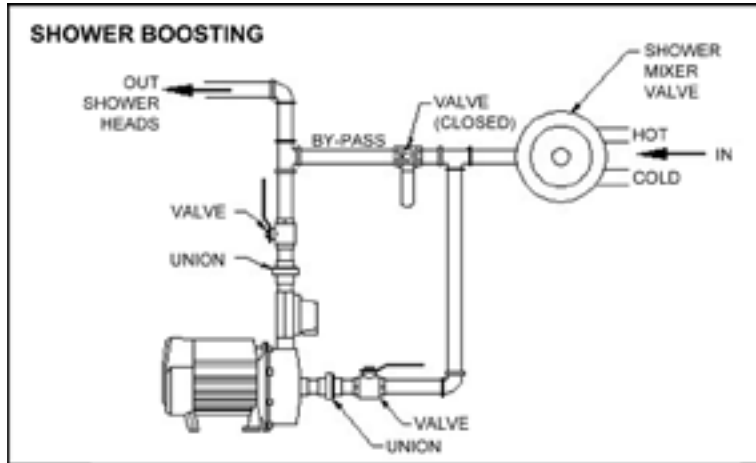

 **Local codes shall govern installation requirements. Unless otherwise specified, the assembly shall be mounted in accordance with the latest edition of the Uniform Plumbing Code. Davey Pumps Inc can not accept responsibility for loss or damage resulting from incorrect or unauthorized installations.**

 **Warning: The heating of water and other fluids causes volumetric expansion. The associated forces may cause failure of system components and release of high temperature fluids. This will be prevented by installing properly sized and located pressure relief valves and compression tanks. Failure to follow these instructions could result in serious personal injury, death, and or property damage.**

 **Do not operate the pressure booster system in a closed system unless the system is constructed with properly sized control devices. These devices include properly sized and located pressure relief valves, compression tanks, and other devices to compensate for thermal expansion.**

 **Abrasive Materials**
The pumping of abrasive materials will cause damage to the pressure system which will then not be covered by the guarantee.

 **DO NOT USE THREAD SEALING COMPOUNDS, HEMP OR PIPE DOPE!**

 **NOTE: Always ensure hot water systems are installed in compliance with manufacturers recommendations and in accordance with all local regulations.**

The control module of the flow switch is free to rotate around the switch, this eliminates the need to do any work on the electrical connections of the flow switch or pump.

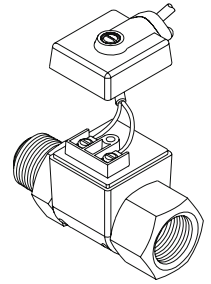

 **Connect power cord to power supply designated on pump label. Do not use long extension cords as they cause substantial voltage drop, poor pump performance and may cause motor overload.**

Electrical Safety

The pump is supplied with a 3-conductor grounding type cord. Connect only to a properly grounded, GFCI protected outlet. Do not lift the pump by the electrical cord.

 **Hazardous voltage. Can shock, burn or cause death. Disconnect the power before working on the pump or motor.**

The pump and controller are non-submersible. Keep the motor dry at all times. Do not wash the motor. Do not immerse. Protect the motor from wet weather.

Do not allow any part of the cord or the receptacle ends to sit in water or in damp locations.

Unplug the pump before servicing.

 **NOTE: Flow switch controller stops pump when flow is below 0.7 gpm.**

Electrical Power Surge Protection

An electrical power surge or spike can travel on the supply lines and cause serious damage to your electrical equipment. The Flow Switch controller fitted to this pump has a metal oxide varistor (MOV) fitted to help protect it's circuit. This MOV is a "sacrificial" device, meaning that it effectively is gradually damaged every time it takes a surge. The MOV is not a lightning arrestor and may not protect the Flow Switch Controller® if lightning or a very powerful surge hits the pump unit.





If the installation is subject to electrical power surges or lightning we strongly recommend the use of suitable additional surge protection devices on ALL electrical equipment.

 **NOTE: For protection, the Davey pump motors are fitted with an automatic reset thermal overload, constant tripping of this overload indicates a problem e.g. low voltage at pump, excessive temperature (above 120°C) in pump enclosure.**



Always disconnect and lockout all electrical power when installing or working on pumps, motor or switches. Insure the power supply breaker is off or the disconnect (where used) is off.



-  Ensure wall socket is correctly grounded. Grounding of the motor is essential for your protection and the protection of the motor.
-  Failure to ground motor can cause severe or fatal electrical shock hazard.
-  Do not ground to a gas supply line.
-  Supply voltage must be within $\pm 10\%$ of nameplate voltage. Incorrect voltage can cause fire or seriously damage motor and voids warranty. If in doubt consult a licensed electrician.
-  If possible, connect pump to a separate branch circuit with no other appliances on it.

Pipe Connections

For best performance use pipes at least the same diameter as the pump's inlet and delivery outlet openings. Larger diameter pipe may be used to minimise resistance to flow when pumping longer distances. When pump is installed with incoming pressure (eg. boosting municipal supply) smaller inlet and outlet pipes may be adequate, but may create noise in the pipe system.

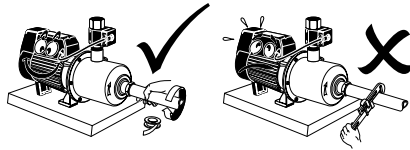

 Do not use pipe thread sealing compound on any part of this pump. Only use teflon sealing tape.

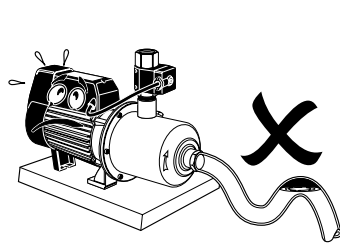

Use unions at pipe connections to enable easy removal and servicing. Use sufficient tape to ensure airtight seal and hand tighten only. To prevent strain on pump threads always support heavy inlet and outlet pipes. If there is a likelihood the water supply may contain solid particles such as pieces of plant or vegetable matter, a filter should be installed before the pump to avoid blocking of water ways. Ensure filter is cleaned regularly. Lay suction pipe at a constant gradient to avoid air pockets which may reduce pump efficiency.

 **NOTE:** Suction leaks are the largest cause of poor pump performance and are difficult to detect. Ensure all connections are completely sealed using thread tape only. An air leak on the suction may not drip water!

Connection to your Water Source

FLOODED SUCTION - FROM MUNICIPAL WATER SUPPLY OR WELL PUMP Connection of Municipal Water Supply to either Suction or Discharge of Pumps & Pressure Systems

Most Water Supply Authorities have strict regulations regarding direct connection of pumps to municipal water supplies. In some cases an isolating tank is required between mains supply and pump. Directly applied municipal pressure can exceed pump operating pressure and damage pump (see table below).

Models	Maximum Inlet Pressure
BF14-30	60 psi
BF20-30	50 psi
BF14-45	40 psi
BF20-40	20 psi

 **NOTE:** The above pressure limits also apply to well pump boosting.

Davey Products Pty Ltd can not accept responsibility for loss or damage resulting from incorrect or unauthorised installations.

Pipe Connections

A pressure reducing valve is required on the suction side of the pump when the incoming pressure is greater than shown on the table above. In some areas, local codes restrict maximum allowable home pressures, and in those cases the pressure reducing valve will need to be set to lower pressures. The chart below shows the applicable settings for the pressure reducing valve.

Local code limits for home pressure	Pressure reducing valve setting (psi)			
	BF14-30	BF20-30	BF14-45	BF20-40
No limit	60psi	50psi	50psi	20psi
80psi	40psi	30psi	30psi	N/A
70psi	30psi	20psi	20psi	N/A

For the BF20-40, the pump produces 76psi at shut off and system pressure will always be at least that plus whatever the incoming pressure is. If discharge pressure must be reduced below that, it may be necessary to put a pressure reducing valve after the discharge of the pump.

Make sure to use adequate Teflon tape on pump inlet and flow sensor threads. **DO NOT USE THREAD PASTE.** This can cause the float to stick inside the sensor. **WHEN SOLDERING COPPER PIPE, MAKE SURE FLUX DOES NOT DRIP INTO FLOW SENSOR.**